

# FLAT PANEL MONITORS

**29LW17X SERIES**

**TFT-for-CRT CHASSIS MONITORS**



## *CRT Monitor Replacements*

- **17" CRT Chassis Monitor dimensions**
- **Uses 15.0" TFT Panel**
- **CGA/EGA/VGA/SVGA/XGA compatible**
- **Programmable for Legacy signals**
- **110/230Vac or 12/24Vdc operation**
- **Adjustable Tilt Positions 0° / 5° / 10° / 15°**
- **Toughened Safety Glass for TFT protection (option of unprotected TFT panel – 17NAX series)**
- **Optional Remote OSD controls**

The **29LW17X series** of Industrial LCD monitors has been designed as replacement for 17" CRT monitors. Ease of integration into a wide range of Measurement, Instrumentation and Human-Machine interface applications has been a key consideration. It uses KME's 29LM153(78UN) series of Minimum Width 15.0" TFT monitors fixed to an Open-frame chassis. Base plate fixings and holes have been designed to pick up on the original CRT chassis mounting positions. .

**Two LCD monitor types are offered: 17AX series for full protection of the TFT panel and best EMC performance; 17NAX series for lowest cost – no Safety Glass or Front Cover.**

	<b>Legacy signals 15kHz -XGA</b>	
Part Nr	29LW17AX71UN	29LW17NAX71UN
Safety Glass Fitted	Yes	No
Front Cover Standard Colour	Black	None
Active Display Area	304 x 228mm	
17" CRT Display Area (typical)	300 x 225mm	
Brightness	250cd/m <sup>2</sup>	
Backlight Life	50,000 hours	
Video Inputs	Analog RGB 0.7Vp-p TTL RGB > 2.75Vp-p via Adapter cable	
Sync. Type/Level	Separate H&V (+/-ve) TTL Composite/Mixed (-ve) TTL Sync-on-Green (-ve) 0.3V	
Input Connectors	BNC x 5 + 15D	
Horizontal Scan Freqy.	15kHz – 60kHz.	
Vertical Scan Freqy.	40 – 100Hz.	
Input Voltage	110/230Vac	
Optional 12Vdc or 24Vdc	Yes	
Power Consumption (approx.)	30W max.	

Due to a policy of continuous product development KME reserves the right to change specifications and descriptions without prior notification. All trade marks acknowledged. 29lw17Xseries1 03/2006



**29LW17X(71UN) SERIES**

**15.0" LCD MONITOR FOR 17" CRT REPLACEMENT**

**REAR VIEW**

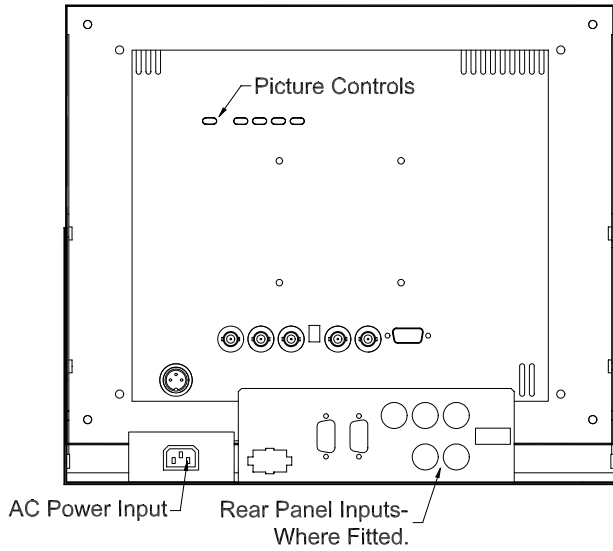

**TOP VIEW**

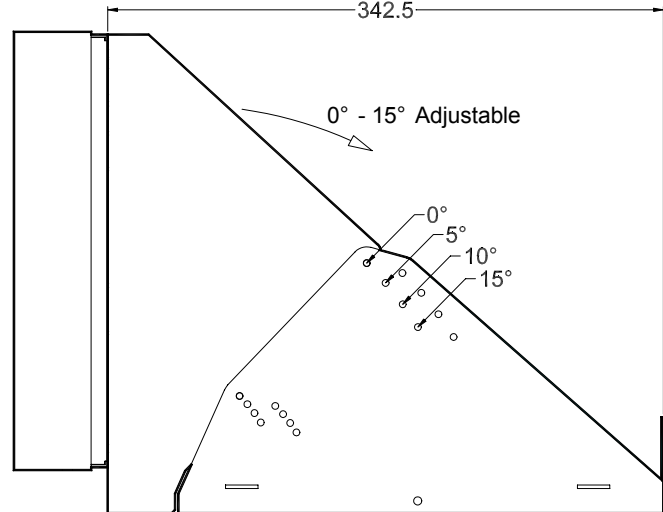
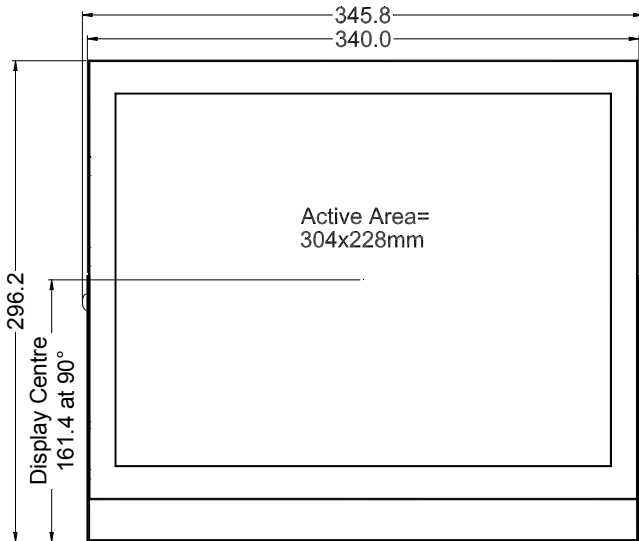
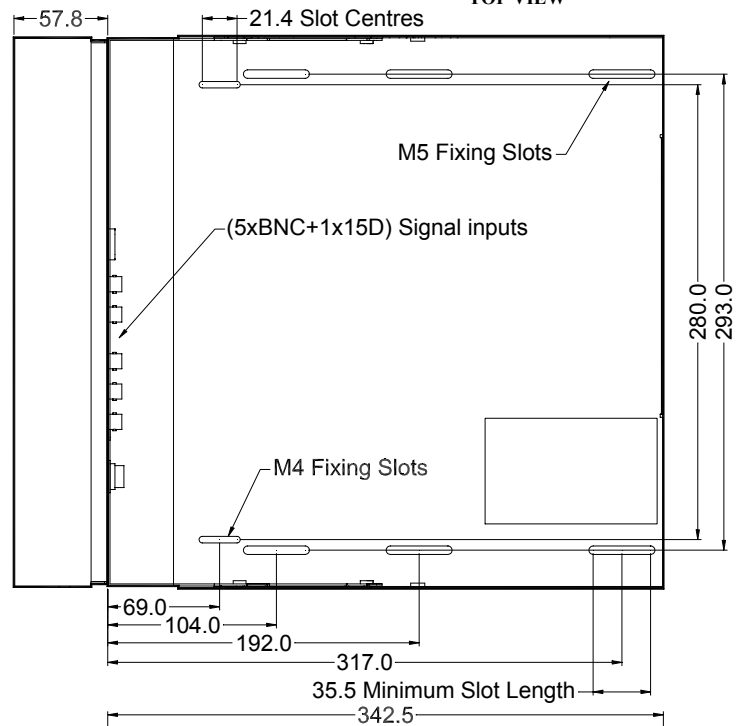

**FRONT VIEW**

**SIDE VIEW**

All dimensions in millimetres  
(Not to scale)

29lw17x(71un)2 03/2006

**Kent Modular Electronics Limited**  
 611 Maidstone Road, Rochester, Kent ME1 3QL, UK  
 Tel: +44 (0) 1634 830123 Fax: +44 (0) 1634 830619  
 E-mail: [sales@kme.co.uk](mailto:sales@kme.co.uk) URL: <http://www.kme.co.uk>

**29LW17NX(71UN) SERIES**

**15.0" LCD MONITOR FOR 17" CRT REPLACEMENT.**

(No Protection Glass or Front Cover)

**REAR VIEW**

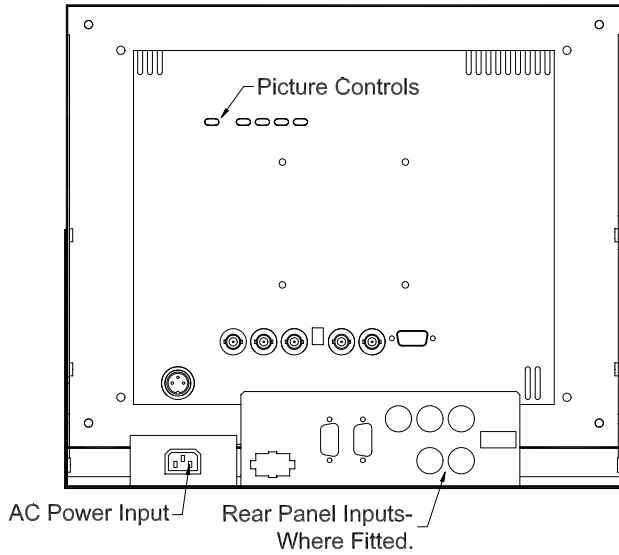

**TOP VIEW**

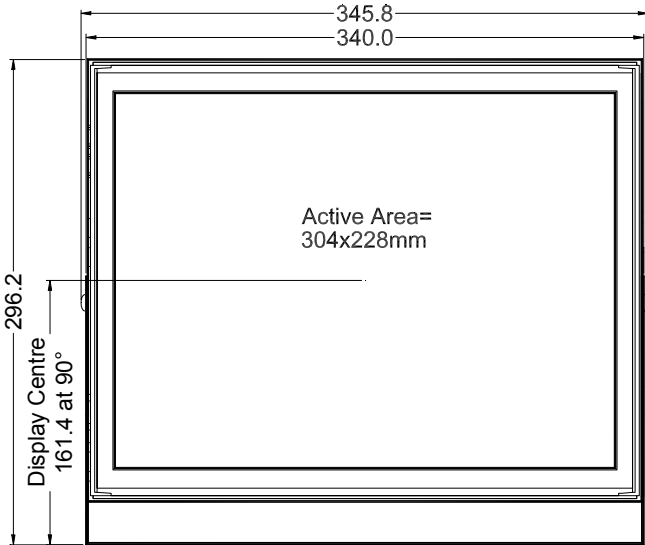
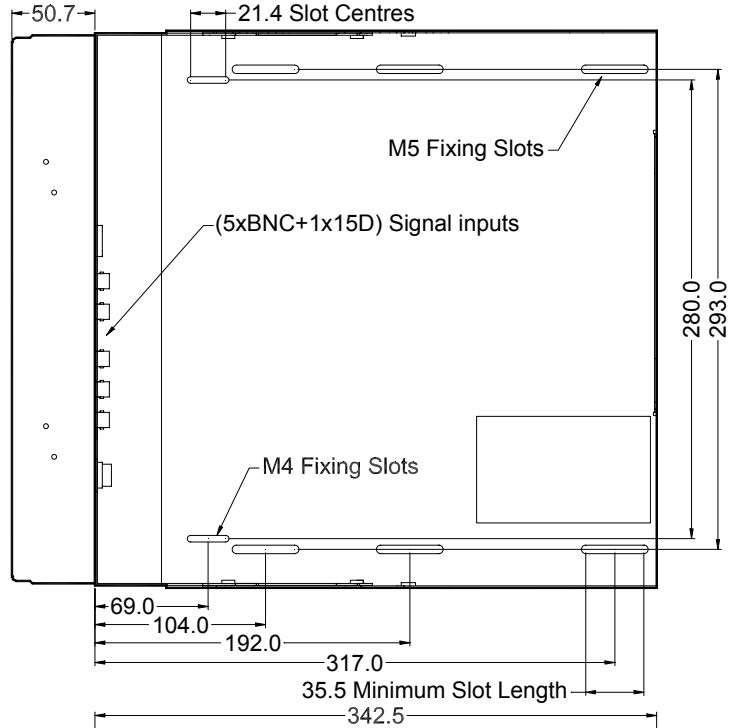

**FRONT VIEW**

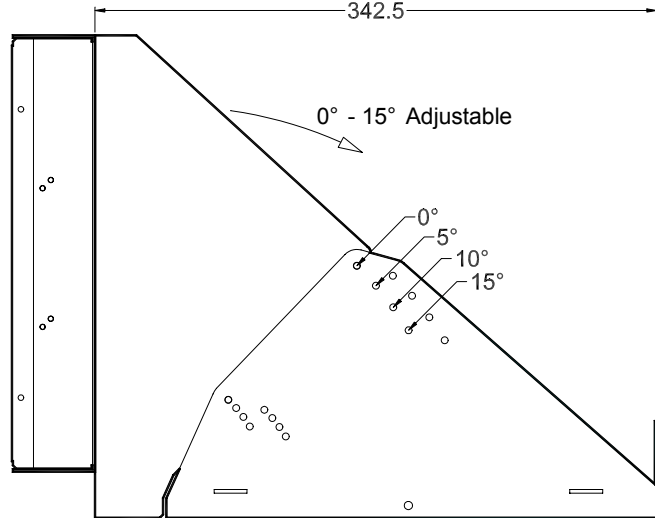

**SIDE VIEW**

All dimensions in millimetres  
(Not to scale)

29lw17nx(71un)2 03/2006

**Kent Modular Electronics Limited**  
 611 Maidstone Road, Rochester, Kent ME1 3QL, UK  
 Tel: +44 (0) 1634 830123 Fax: +44 (0) 1634 830619  
 E-mail: [sales@kme.co.uk](mailto:sales@kme.co.uk) URL: <http://www.kme.co.uk>